

Miele

Operating and installation instructions



Fridge-freezer with PerfectFresh zone and Dynamic cooling KF 9757 iD

To avoid the risk of accidents or damage to the appliance, it is **essential** to read these instructions before it is installed and used for the first time.

en - GB

M.-Nr. 07 472 710

Contents

Guide to the appliance	5
Caring for the environment	7
Warning and Safety instructions	8
How to save energy	13
Switching on and off	14
To switch the refrigerator section/PerfectFresh zone off separately	15
Safety lock	15
Switching off for longer periods of time	16
The correct temperature	17
. . . in the refrigerator and the PerfectFresh zone	17
Dynamic cooling	17
. . . in the freezer section	17
Setting the temperature in the refrigerator section / freezer section	18
Temperature range	18
Setting the temperature in the PerfectFresh zone	18
Temperature display	19
Temperature display brightness	20
Alarm	21
Activating the alarm system	21
Switching the alarm off early	21
Super cool and Super freeze	22
Super cool	22
Super freeze	22
Using the refrigerator efficiently	24
Different storage zones	24
Food which should not be stored in a refrigerator	25
When shopping for food	25
Storing food correctly	25
Unpacked meat and vegetables	25
Using the PerfectFresh zone	26
Storage temperature	26
Humidity level	26
Storing food in the dry and humidity-controlled compartments	26
The dry compartment	26
Humidity-controlled compartment	27

Adjusting the interior fittings	28
Moving the shelves	28
Split shelf	28
Adjusting the condiment tray/bottle shelf	29
Universal container	29
Moving the bottle divider	29
Freezing and storing food	30
Maximum freezing capacity	30
Freezing fresh food	30
Storing frozen food	30
Home freezing	31
Hints on home freezing	31
Packing	31
Before placing food in the freezer section	32
Placing food in the freezer	32
Freezing large items	32
Freezer calendar	32
Defrosting	33
Ice cubes	33
Cooling drinks	33
Freezer tray	34
Cool pack	34
Defrosting the appliance	35
Refrigerator and PerfectFresh zone	35
Freezer section	35
Cleaning and care	37
E-Cloth	37
Cleaning the interior and accessories	37
Ventilation gaps	38
Door seals	38
Problem solving guide	39
Noises	43
After Sales / Guarantee	44
Electrical connection	45

Contents

Installation	46
Location	46
Climate range	46
Ventilation	47
Before installation	47
Does your old appliance have a different hinging mechanism?	47
Building-in dimensions	48
Adjusting the door hinges	49
Changing the door hinging	50
Building in the appliance	53
Weight of the furniture doors	53
Building into a peninsular run	53
Fitting the furniture doors.	58

Guide to the appliance

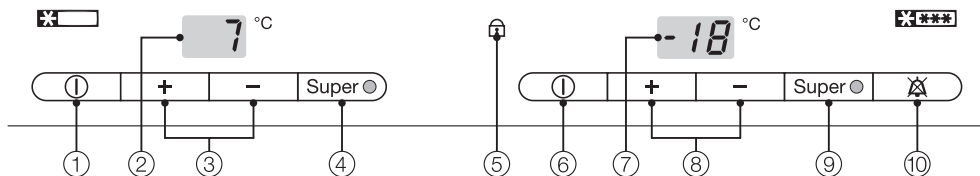

- ① On/Off button for switching the refrigerator section / PerfectFresh zone on and off separately.
- ② Refrigerator section temperature display
- ③ Refrigerator section temperature selector buttons (+ for warmer; – for colder)
- ④ Super cool button and indicator light
- ⑤ Safety lock indicator light
- ⑥ Master switch for switching the whole appliance on and off
- ⑦ Freezer section temperature display
- ⑧ Freezer section temperature selector buttons (+ for warmer; – for colder)
- ⑨ Super freeze button and indicator light
- ⑩ Alarm off button

Guide to the appliance

- ① Fan for Dynamic cooling
- ② Adjustable shelves
- ③ PerfectFresh zone, dry compartment
- ④ Control for setting the moisture level in the humidity controlled compartment
- ⑤ PerfectFresh zone, humidity controlled compartment
- ⑥ Butter and cheese compartment
- ⑦ Egg tray/Condiment tray with universal container
- ⑧ Interior lighting
- ⑨ Bottle divider*
- ⑩ Bottle shelf
- ⑪ Condensate channel and drain hole
- ⑫ Freezer drawers with freezer calendar

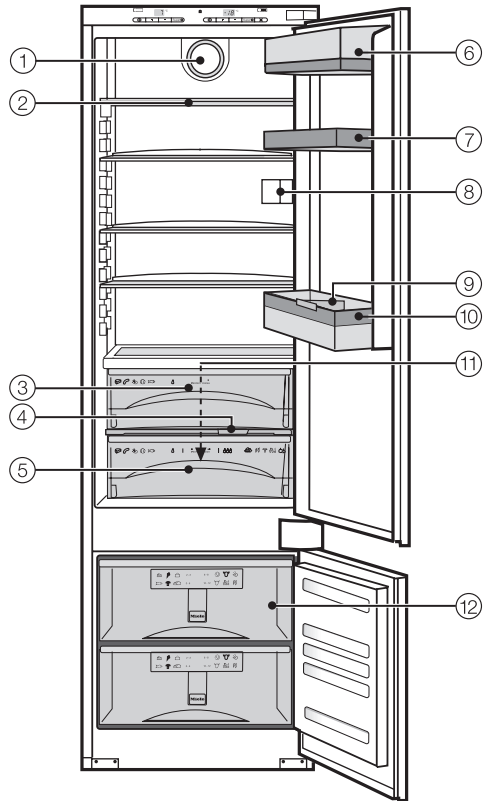

* Depending on model

Disposal of the packing material

The transport and protective packing has been selected from materials which are environmentally friendly for disposal, and should be recycled.

Ensure that any plastic wrappings, bags etc. are disposed of safely and kept out of the reach of babies and young children. Danger of suffocation!

Disposal of your old appliance

Electrical and electronic appliances often contain materials which, if handled or disposed of incorrectly, could be potentially hazardous to human health and to the environment. They are, however, essential for the correct functioning of your appliance. Please do not therefore dispose of it with your household waste.

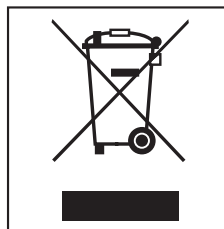

Please dispose of it at your local community waste collection / recycling centre or contact your dealer for advice. Ensure that it presents no danger to children while being stored for disposal.

Take care not to damage the pipework at the back of it before or during transportation to an authorised collection depot.

In this way, refrigerant in the pipework and oil in the compressor will be contained, and will not leak out into the environment.

Warning and Safety instructions

This appliance complies with all relevant legal safety requirements. Improper use of the appliance can, however, present a risk of both personal injury and material damage.

To avoid the risk of accidents and damage to the appliance, please read these instructions carefully before installation and before using it for the first time. They contain important notes on the installation, safety, operation and care of the appliance.

Keep these instructions in a safe place and pass them on to any future user.

Correct application

► This appliance is not designed for commercial use. It is intended for use in domestic households and in similar working and residential environments such as:

- Shops
- Offices and showrooms
- Hostels and guest houses.

It must only be used as a domestic appliance to cool and store foodstuffs as well as to store deep frozen food, freeze fresh food and to prepare ice.

Any other usage is not supported by the manufacturer and could be dangerous. Miele cannot be held liable for damage resulting from incorrect or improper use or operation of the appliance.

► This appliance is not intended for use by persons (including children) with reduced physical, sensory or mental capabilities, or lack of experience and knowledge, unless they have been given supervision or instruction concerning use of the appliance by a person responsible for their safety.

Safety with children

► This appliance is not a toy! To avoid the risk of injury, do not allow children to play on or near it or to play with the controls. Older children may only use the appliance if its operation has been clearly explained to them and they are able to use it safely, recognising the dangers of misuse.

► Keep children away from the appliance at all times and supervise them whilst you are using it. Do not allow children to play with the appliance, for example to climb inside the drawers or to swing on the door.

Warning and Safety instructions

Technical safety

► Before setting up the appliance, check it for any externally visible damage.

Do not install and use a damaged appliance.

► This appliance contains the coolant Isobutane (R600a), a natural gas which is environmentally friendly. Although it is flammable, it does not damage the ozone layer and does not increase the greenhouse effect. The use of this environmentally friendly coolant has, however, led to a slight increase in the noise level of the appliance. In addition to the noise of the compressor, you might be able to hear the coolant flowing around the system. This is unavoidable, but does not have any adverse effect on the performance of the appliance.

Care must be taken during the transportation and setting up of the appliance that no parts of the cooling system are damaged. Leaking coolant can damage the eyes.

In the event of any damage:

- avoid open fires and anything which creates a spark,
- disconnect from the mains,
- air the room in which the appliance is located for several minutes and
- contact the Service Department for advice.

► The more coolant there is in an appliance, the larger the room it should be installed in. In the event of a leakage, if the appliance is in a small room, there is the danger of combustible gases building up.

For every 8 g of coolant at least 1 m³ of

room space is required. The amount of coolant in the appliance is stated on the data plate inside the appliance.

► Before connecting the appliance to the mains supply, make sure that the voltage and frequency correspond to the rating on the data plate.

This data must correspond in order to avoid the risk of damage to the appliance. Consult a qualified electrician if in any doubt.

► The electrical safety of this appliance can only be guaranteed when continuity is complete between it and an effective earthing system which complies with current local and national safety regulations. It is most important that this basic safety requirement is present and tested regularly, and where there is any doubt, the household wiring system should be inspected by a qualified electrician. The manufacturer cannot be held liable for damage or injury caused by the lack of or inadequacy of an effective earthing system (e.g. electric shock).

► If the connection cable is faulty it must only be replaced by a Miele approved service technician to protect the user from danger.

Warning and Safety instructions

▶ Safe operation of the appliance is only assured if it has been installed and connected in accordance with these operating and installation instructions.

▶ This equipment may only be used in mobile installations such as ships, caravans, aircraft etc. if a risk assessment of the installation has been carried out by a suitably qualified engineer.

▶ Installation work, maintenance and repairs may only be carried out by suitably qualified and competent persons in accordance with national and local safety regulations. Repairs and other work by unqualified persons could be dangerous and the manufacturer will not be held liable. Ensure current is not supplied to the appliance until after maintenance or repair work has been carried out.

▶ The appliance is only completely isolated from the electricity supply when:

- it has been switched off at the wall socket and the plug has been withdrawn.
- the fuse from the fused spur connection unit has been withdrawn, or
- the mains fuse has been withdrawn, or the screw-out fuse removed (in countries where this is applicable).

▶ Do not connect the appliance to the mains electricity supply by an extension lead.

Extension leads do not guarantee the required safety of the appliance (e.g. danger of overheating).

▶ In countries where there are areas which may be subject to infestation by cockroaches or other vermin, pay particular attention to keeping the appliance and its surroundings in a clean condition at all times. Any damage which may be caused by cockroaches or other vermin will not be covered by the appliance guarantee.

Correct use

▶ Never handle frozen food with wet hands. Your hands may freeze to the frozen food.

▶ Do not take ice cubes out with your bare hands and never place ice cubes or ice lollies in your mouth straight from the freezer.

The very low temperature of the frozen ice or lollies can cause frost burn to the lips and tongue.

▶ Do not re-freeze thawed or partially thawed food.

Defrosted food should be used up as quickly as possible as food soon loses its nutritional value and goes off.

Defrosted food may only be re-frozen after it has been cooked.

Warning and Safety instructions

▶ Do not store explosive materials in the appliance or any products containing propellants (e.g. spray cans). Thermostats switching on may produce sparks which could present a fire hazard. Flammable compounds could explode.

▶ Do not operate any electrical equipment (e.g. an electric ice-cream maker) inside the appliance. Danger of sparking and explosion.

▶ If storing alcohol with a high percentage proof, make sure it is tightly closed and stored upright. Danger of explosion.

▶ Do not store cans or bottles containing carbonated drinks or liquids which could freeze in the freezer section. The cans or bottles could explode. Danger of injury and damage to the appliance.

▶ When cooling drinks quickly in the freezer make sure bottles are not left in for more than one hour, otherwise they could burst, causing injury or damage.

▶ Observe the "use by" dates given on food to avoid the risk of food poisoning. Storage times will depend on several factors, including the freshness and quality of the food as well as the temperature at which it is stored. Follow the instructions given on the food manufacturer's packaging on storage conditions required.

- ▶ Do not use sharp edged objects to
- remove frost and ice,
 - separate frozen foods and remove ice trays.

They will damage the evaporator, causing irreversible damage to the appliance.

▶ Never place electric heaters or candles in the appliance to defrost it. These can damage the plastic parts.

▶ Do not use defrosting sprays or de-icers, as they might contain substances which could damage the plastic parts or which could cause a build-up of gases and pose a danger to health.

▶ Do not use mechanical devices or other means to accelerate the defrosting process, other than those recommended by the manufacturer.

▶ Do not use any oils or grease on the door seals, as these will cause the seals to deteriorate and become porous with time.

▶ Do not store cooking oil in the refrigerator door. Traces of oil can cause stress cracks to occur in the plastic components in the door.

▶ Do not block the ventilation gap in the plinth or the top of the appliance housing unit as this would impair the efficiency of the appliance, increase the electricity consumption and could cause damage to the appliance.

Warning and Safety instructions

▶ The appliance is designed for use within certain climate ranges (ambient temperatures), and should not be used outside this range. The climate range for your appliance is stated on the data plate inside the appliance.

Installing it in a room with too low an ambient temperature, e.g. a garage, can lead to the appliance switching off for longer periods so that it cannot maintain the required temperature.

▶ Never use a steam-cleaning appliance to defrost or clean this appliance. Pressurised steam could reach the electrical components and cause a short circuit.

▶ In countries where there are areas which may be subject to infestation by cockroaches or other vermin, pay particular attention to keeping the appliance and its surroundings in a clean condition at all times. Any damage which may be caused by cockroaches or other vermin will not be covered by the guarantee.

Disposal of your old appliance

▶ Before disposing of an old appliance, first make the door latch or lock unusable.

This way you will prevent children from accidentally locking themselves in and endangering their lives.

▶ Be careful not to damage any part of the pipework whilst awaiting disposal, e.g. by

- puncturing the refrigerant channels in the evaporator.
- bending any pipework.
- scratching the surface coating.

Splashes of refrigerant can damage the eyes.

The manufacturer cannot be held liable for damage caused by non-compliance with these Warning and Safety instructions.

How to save energy

	Normal energy consumption	Increased energy consumption
Installation site	In a ventilated room.	In an enclosed, unventilated room.
	Protected from direct sunlight.	In direct sunlight.
	Not situated near to a heat source (radiator, oven).	Situated near to a heat source (radiator, oven).
	Where the ideal ambient room temperature is approx. 20°C.	Where there is a high ambient room temperature.
Temperature setting with a thermostat which is approximate (set in stages).	With a medium setting of 2 to 3.	With a high setting: the lower the temperature in the compartment, the higher the energy consumption.
Temperature setting with a thermostat which is exact to the degree (digital display).	Cellar section 8 to 12°C	On appliances with winter setting, please make sure that the winter setting is switched off when the ambient temperature is warmer than 16 °C.
	Refrigerator section 4 to 5 °C	
	PerfectFresh zone just above 0 °C	
	Freezer section -18°C	
	Wine storage section 10 to 12 °C	
Use	Only open the doors when necessary and for as short a time as possible.	Frequent opening of the doors for long periods will cause a loss of coldness.
	Store food in an organised way.	If food is not stored in an organised way, searching for an item will mean the door is open for longer.
	Allow hot food and drinks to cool down before placing them in the appliance.	Placing hot food in the appliance will cause the compressor to run for a long time, as the appliance will have to work harder to lower the temperature.
	Store food covered or packaged.	The evaporation or condensation of liquids will cause a loss of coldness in the refrigerator.
	Place frozen food in the refrigerator to defrost.	
	Do not over-fill the appliance to allow air to circulate.	
Defrosting	Defrost the freezer compartment when a layer of ice 0.5 cm thick has built up.	A layer of ice hinders the cold from reaching the frozen food, and causes an increase in energy consumption.

Switching on and off

Before using for the first time

The stainless steel trim to the interior shelves and the door shelves has a layer of protective foil to prevent scratching during transportation.

- Do not remove this foil until the appliance has been built in.
- Treat the stainless steel surfaces with a proprietary stainless steel conditioner immediately after removing the foil (available from the Miele Spare Parts department or via the internet on www.miele.co.uk).

Important! A stainless steel conditioner gives long lasting protection, and helps to prevent resoiling.

- Clean the inside of the appliance and the accessories with warm water and a little washing-up liquid, and then dry with a soft cloth.

Important:
To ensure the correct functioning of the appliance, let it stand for between 1½ and 2 hours after transporting it to its final location before connecting it to the mains.

Switching on

The refrigerator section/PerfectFresh zone and freezer section are switched on together by pressing the master switch on the right hand side of the control panel.

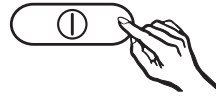

- Press the master switch on the right hand side of the control panel.

The temperature display for the refrigerator section lights up, and the interior lighting comes on when the door is opened.

Bars light up in the temperature display for the freezer section.

The appliance starts cooling.

To enable the temperature to get sufficiently cold inside the appliance, allow the appliance to run for a few hours before placing food in it.

Cool pack

Place the cool pack in the top freezer drawer or, to save space, on the freezer tray. The cool pack will be at its most effective after it has been in the freezer for approx. 24 hours.

Switching off

- Press the master switch on the right hand side of the control panel until both temperature displays go out.

The cooling system is switched off. If this does not happen, then the safety lock has been activated.

To switch the refrigerator section/PerfectFresh zone off separately

The refrigerator section/PerfectFresh zone can be switched off without having to switch off the freezer section. This is useful e.g. whilst on holiday.

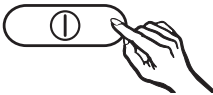

- Press the On/Off button for the refrigerator section/PerfectFresh zone on the left hand side of the control panel until the temperature display for the refrigerator section goes out.

To switch the refrigerator section/PerfectFresh zone back on again

- Press the On/Off button on the left hand side of the control panel again.

The refrigerator section temperature display lights up. The refrigerator section/PerfectFresh zone starts cooling. The interior light will come on when the door is opened.

Safety lock

The safety lock can be activated to prevent the appliance being switched off inadvertently.

Activating or de-activating the safety lock

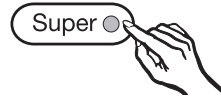

- Press and hold the Super freeze button for approx. 5 seconds.

The Super freeze indicator light flashes, and **c** flashes in the temperature display.

- Then press the Super freeze button again.

c will light up in the display.



- You can now choose between **c** **0** and **c** **1** by pressing the temperature selector buttons:
0: the safety lock is de-activated,
1: the safety lock is activated.
- Press the Super freeze button to save the setting.

The safety lock indicator light  will light up when the safety lock has been activated.

Switching on and off

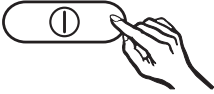

- Press the master switch on the right hand side of the control panel to come out of the setting mode.

If you do not do this, the electronics will switch over to normal operation automatically after a couple of minutes.

Switching off for longer periods of time

If the appliance is not going to be used for a longer period of time, e.g. whilst on holiday:

- switch the appliance off,
- switch off at the wall socket and withdraw the plug,
- defrost the freezer, clean the appliance and
- leave the doors ajar to air the appliance.

If, during a long absence, the appliance is switched off but not cleaned out and the doors are left shut, there is a danger of mould and odours building up inside the appliance.

The correct temperature

It is very important to set the correct temperature for storing food in the appliance. Micro-organisms will cause food which is not stored at the correct temperature to deteriorate rapidly. Temperature influences the growth rate of these micro-organisms. Reducing the temperature reduces their growth rate.

The temperature in the appliance will rise:

- the more often the door is opened and the longer it is kept open,
 - the more food that is stored in the appliance,
 - the warmer the food is which is being put into it,
 - the higher the ambient temperature surrounding the appliance.
- The appliance is designed for use in specific ambient temperatures (climate ranges). Do not use in ambient temperatures for which it is not designed.

. . . in the refrigerator and the PerfectFresh zone

We recommend a temperature of **4 °C** in the refrigerator.

The temperature in the PerfectFresh zone is controlled automatically, and is maintained at **0 to 3 °C**.

Dynamic cooling

The dynamic cooling fan automatically switches on when the cooling system for the refrigerator switches on. It distributes the temperature in the appliance to all areas more evenly so that all the food will be chilled to about the same degree.

. . . in the freezer section

To freeze fresh food and to store frozen food for a long time, a temperature of **-18 °C** is required. At this temperature the growth of micro-organisms is generally halted. As soon as the temperature rises above -10 °C, the micro-organisms become active in the food again so that it cannot be kept as long. For this reason, partially defrosted or defrosted food must not be re-frozen. Food may be re-frozen once it has been cooked, as the high temperatures achieved when cooking destroy most micro-organisms.

The correct temperature

Setting the temperature in the refrigerator section / freezer section

Use the two buttons underneath the respective temperature displays to set the temperature for the refrigerator and freezer sections.

Press the



- + button: to raise the temperature (it gets warmer)
- button: to reduce the temperature (it gets cooler).

The temperature being set will flash in the display.

When pressing the buttons, the following information shows in the display:

- When first pressed, the **last temperature selected** flashes.
- Each subsequent press of the button adjusts the temperature shown in 1 °C steps.
- Keeping the button pressed in adjusts the temperature continually.

Approx. 5 seconds after letting go of the button the **current, average** temperature of the refrigerator or freezer section is automatically shown.

If you have adjusted the temperature, **wait for approx. 6 hours if the appliance is not very full** and **for approx. 24 hours if the appliance is full** before checking the temperature

display, as it will take this long for the display to give an accurate reading. If, after this time, the temperature is still too high or too low, you will need to adjust it again.

Temperature range

The temperature can be adjusted:

- In the refrigerator section from 4 °C to 9 °C
- In the freezer section from -16 °C to -26 °C.

The ambient temperature in the room and the installation location can affect the time it takes for the appliance to reach the lowest temperature. If the ambient temperature is too high, the appliance may not reach the lowest temperature.

Setting the temperature in the PerfectFresh zone

The temperature in the PerfectFresh zone is automatically held at 0 to 3 °C. It can be raised or lowered, e.g. if you want to use it for storing items like fish.

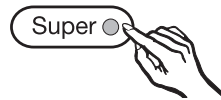

- Press and hold the Super freeze button for approx. 5 seconds.

The Super freeze indicator light will start flashing, and a **■** will flash in the temperature display.

The correct temperature



- Press one of the temperature selector buttons repeatedly until a **b** appears in the display. Then press the Super freeze button again.

b lights up in the display.

- You can now adjust the temperature in the PerfectFresh zone by pressing the temperature selector buttons. You can choose from settings **1** to **9**:
1: lowest temperature,
9: highest temperature.

b 5 is the default setting for the PerfectFresh zone. If a setting of **b 1** to **b 4** is selected, the temperature can fall below 0°C. Food could freeze!

- Press the Super freeze button to save the setting.

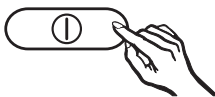

- Press the master switch on the right hand side of the control panel to come out of the setting mode.

Otherwise the electronics will revert to normal operation after a couple of minutes.

The new temperature setting for the PerfectFresh zone takes effect gradually.

Temperature display

During normal operation, the temperature displays on the control panel show the temperature in the middle of the refrigerator section and the temperature in the warmest part of the freezer section.

If the temperatures in the appliance are not within the range that the appliance is able to display, bars will flash in the temperature displays.

The **temperature displays flash** if

- a different temperature is being set,
- the temperature in the appliance has risen by several degrees, indicating that the appliance is warming up too much.

This loss of coldness is no cause for concern in the following circumstances:

- when the door has been left open for a while, e.g. for removing or storing a large amount of food,
- when fresh food is being frozen.

However, if the temperature in the freezer section remains above -18 °C for a long time, check that the frozen food has not started to defrost. If it has started thawing, check that the food is safe to use and if it is, use it as quickly as possible.

The correct temperature

Temperature display brightness

The appliance is supplied with the brightness of the temperature display set as low as possible. However, if the door is opened, a setting changed or if the alarm is sounding, the temperature display will appear much brighter for approx. 1 minute.

The level of brightness can be adjusted:

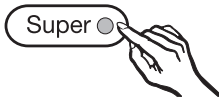

- Press and hold the Super freeze button for approx. 5 seconds.

The Super freeze indicator light flashes and a  flashes in the temperature display.



- Press one of the temperature selector buttons repeatedly until **h** appears in the display.
 - Then press the Super freeze button again.
- h** lights up in the display.
- You can now adjust the level of brightness by pressing the temperature selector buttons. You can choose from settings **1** to **5**:
1: dimmest setting,
5: brightest setting.
 - Press the Super freeze button to save the setting.

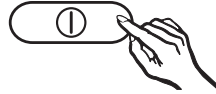

- Press the master switch on the right hand side of the control panel to come out of the setting mode.

Otherwise the electronics will revert to normal operation after a couple of minutes.

Your appliance has been fitted with a warning system which ensures that the temperature in the freezer section cannot rise unnoticed.

An alarm will sound and at the same time the temperature display for the freezer section will flash if the temperature becomes too warm. The temperature the appliance is set at determines the temperature the appliance recognises as being too warm.

The alarm will sound and the alarm indicator light will flash,

- if the freezer door has been left open for a while, e.g. in order to load, to re-arrange or to take food out.
- when freezing large amounts of food at once.

Activating the alarm system

The alarm system is always active. It does not have to be switched on manually.

Switching the alarm off early

Once the set temperature has been reached in the freezer, the alarm switches off and the temperature display stops flashing and lights up constantly. However, if the noise disturbs you, you can switch the alarm off before this if you wish.



- Press the alarm off button.

The alarm will stop. The temperature display will continue to flash until the set temperature has been reached. The display then stops flashing and lights up constantly. The alarm system is now fully active once more.

Super cool and Super freeze

Super cool

The Super cool function can be used to rapidly reduce the temperature in the refrigerator section to its lowest setting (depending on the room temperature).

Switching on Super cool

Super cool is particularly recommended for the faster chilling of large amounts of fresh food or drink.

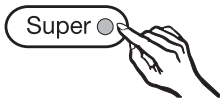

- Press the Super cool button; the Super cool indicator light will come on.

The appliance works at full power to lower the temperature in the refrigerator section.

Switching off Super cool

The Super cool function will switch itself off automatically after approx. 6 hours. The indicator light will go out and the appliance will run at normal power again.

To save energy, the Super cool function can be switched off once food and drinks are sufficiently chilled.

- Press the Super cool button. The Super cool indicator light will go out, and the appliance will continue to operate at normal power.

Super freeze

Switch the Super freeze function on before putting fresh food into the freezer.

This helps food to freeze quickly and retain its nutrients, vitamins, flavours and appearance.

Super freeze is not necessary:

- when putting in food that is already frozen.
- when freezing up to 2 kg fresh food daily.

Switching on Super freeze

When freezing small quantities of food in the freezer, the Super freeze function should be switched on **6 hours beforehand**. When freezing **the maximum load of food** the Super freeze function should be switched on **24 hours beforehand**.

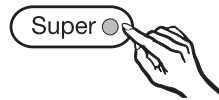

- Press the Super freeze button. The Super freeze indicator light will come on.

The appliance works at full power to lower the temperature in the freezer section.

Switching off Super freeze

Depending on the amount of food placed in the freezer section, the Super freeze function will switch off automatically after approx. 30 to 60 hours. The Super freeze indicator light will go out and the appliance will continue running at normal power.

To save energy, the Super freeze function can be switched off once a constant temperature of $-18\text{ }^{\circ}\text{C}$ or colder has been reached in the freezer section.

- Press the Super freeze button. The Super freeze indicator light will go out, and the appliance will continue to operate at normal power.

Using the refrigerator efficiently

Different storage zones

Due to the natural circulation of the air in the appliance, there are different temperature zones in the refrigerator. Cold, heavy air sinks to the lowest section of the appliance. Make use of the different zones when placing food in the appliance.

This appliance has automatic dynamic cooling, which helps to keep an even temperature when the fan is running. For this reason, the difference between the various zones is less pronounced.

Warmest area

The warmest area is in the top section of the door. Use this for storing butter and cheese.

Coldest area

The coldest area in the refrigerator is directly above the PerfectFresh zone. However, the PerfectFresh zone is even colder.

Use these areas in the refrigerator and in the PerfectFresh zone for all delicate and highly perishable food, e.g.

- fish, meat, poultry,
- sausage products, ready meals,
- dishes or baked goods containing eggs or cream,
- fresh dough, cake mixtures, pizza or quiche dough,
- soft cheese and other dairy products,

- pre-packed vegetables and other fresh food with a label stating it should be kept at a temperature of approx. 4 °C.

Do not store explosive materials in the appliance or any products containing propellants (e.g. spray cans). Danger of explosion.

If storing alcohol with a high percentage proof, make sure it is tightly closed, and store upright.

Do not store cooking oil in the refrigerator door. Traces of oil can cause stress cracks to occur in the plastic components in the door.

Food must not touch the back wall of the refrigerator, as it may freeze to the back wall.

To allow air to circulate efficiently, do not pack food too closely together in the refrigerator. Do not cover the fan in the rear wall of the refrigerator, as this is essential for keeping the appliance cool.

Using the refrigerator efficiently

Food which should not be stored in a refrigerator

Not all food is suitable for refrigeration. This includes:

- Fruit and vegetables which are sensitive to cold, such as bananas, avocado, papaya, passion fruit, aubergines, peppers, tomatoes and cucumbers
- Fruit which is not yet ripe
- Potatoes
- Some hard cheeses, e.g. Parmesan

When shopping for food

The freshness of food when first placed in the appliance is an important factor in determining how long it stays fresh, and how long it can be kept in the refrigerator. Time out of the refrigerator, e.g. during transportation, should be kept to a minimum. For example, do not allow food to stay in a hot car for too long. Once food has started to deteriorate, this process cannot be reversed. As little as two hours outside the refrigerator can cause food to start deteriorating.

Storing food correctly

Food should generally be stored covered or packaged in the refrigerator (there are some exceptions to this rule in the PerfectFresh zone - see below). This will prevent food smells from affecting other foods, food from drying out, and also any cross-contamination of bacteria. The growth of bacteria, such as salmonella, can be avoided by setting the correct temperature and maintaining good standards of hygiene.

Unpacked meat and vegetables

Unpackaged meat and vegetables should be stored separately. To avoid any microbiological cross-contamination, these foods may only be stored together if they are wrapped.

Using the PerfectFresh zone

For every type of food, there are ideal storage conditions to ensure it stays fresh as long as possible, retaining both flavour and vitamins.

The important factors for this are the storage temperature and the humidity.

The correct combination of temperature and humidity is a unique feature of the PerfectFresh zone. Food can be stored for up to three times longer in the PerfectFresh zone than in a standard refrigerator.

Storage temperature

The optimum storage temperature for fresh food which is not sensitive to the cold is 0 - 3 °C. This is the temperature range which is automatically maintained in the PerfectFresh zone.

Food can be stored there at this temperature without loss of freshness for considerably longer than in a standard refrigerator, as the deterioration process is decelerated at this temperature.

Humidity level

The closer the storage humidity is to the humidity content of the food, the crisper and fresher the food remains over a longer period, as the water content of the food is largely retained.

What are the advantages of the PerfectFresh zone?

As food remains fresh for up to three times as long, the advantages for you are:

- fresher, tastier food,
- greater convenience due to practical storage, and
- greater savings due to quality preservation.

Storing food in the dry and humidity-controlled compartments

The PerfectFresh zone is divided into two areas, the dry compartment and the humidity-controlled compartment.

The dry compartment

The dry compartment has a relatively low humidity level that is approx. the same as that in the refrigerator.

So the main advantage of the dry compartment is the low temperature of 0 °C, rather than the humidity.

The dry compartment is ideal for storing particularly sensitive foods, such as

- fresh fish, shellfish, meat, poultry, sausages, dairy products and salads.

Please note that foods rich in protein deteriorate faster than others.

Shellfish, for example, deteriorates faster than fish, and fish deteriorates faster than meat.

Always keep these foods **covered or wrapped**.

Exception: Meat. The surface of the meat dries out slightly, helping to prevent the growth of bacteria, which results in the meat lasting longer. To prevent the risk of bacterial cross-contamination and meat deteriorating, do not let one type of meat come into direct contact with another type.

Humidity-controlled compartment

The humidity-controlled compartment has a regulator which is used to adjust the relative humidity. Slide the regulator to the relative humidity level required (▲▲▲ = high humidity, ▲ = low humidity).

If high humidity ▲▲▲ is selected, a humidity level of 90 % can be achieved when the compartment is full. The humidity depends strongly on the type and quantity of food being stored.

Please take into account that high humidity is only achieved and is only effective on the food if the food is stored **unwrapped or loosely wrapped**.

- The humidity-controlled compartment at the high humidity setting ▲▲▲ is ideal for storing freshly harvested products such as vegetables, salad, herbs, mushrooms and home-grown seasonal fruit.
- At the low humidity setting ▲, the atmosphere inside the humidity-controlled compartment is the same as in the dry compartment.

Take food out of the PerfectFresh zone approx. 30 - 60 minutes before using it. The aroma and taste do not fully develop until the food has reached room temperature.

Can all types of food be stored together?

Do not place all types of food together in one drawer. Some types of food do not store well together. Aromas and flavours can transfer from one type of food to another (e.g. carrots absorb the smell and flavour of onions very easily). Some food also gives off a natural gas (ethylene) which speeds up the rate at which other food perishes.

Examples of fruit and vegetables which produce a large amount of this natural gas are:

Apples, apricots, pears, nectarines, peaches, plums, avocado, figs, blueberries, melons and beans.

Examples of fruit and vegetables which react strongly to the natural gases given off by other types of fruit and vegetables are:

Kiwis, broccoli, cauliflower, Brussels sprouts, mangos, honeydew melons, apples, apricots, cucumbers, tomatoes, pears, nectarines and peaches.

Example: Broccoli should not be stored with apples, as apples produce a large amount of natural gas to which broccoli is very sensitive. The result is a shorter than expected storage time for the broccoli.

Adjusting the interior fittings

Moving the shelves

The shelves can be adjusted according to the height of the food.

- Raise the shelf, and pull it forwards slightly until the notch at the side is in line with the shelf support. It can then be raised or lowered to the required level.

The raised edge at the back must face upwards to prevent food from touching the back of the appliance and freezing to it.

Stoppers prevent the shelves from being dislodged by mistake.

Split shelf

In order to accommodate tall items in the appliance, one of the shelves is divided. The front section can be pushed under the rear section.

- Push the rear half of the glass shelf up slightly from below.
- At the same time, pull the front half of the glass shelf forwards slightly and then push it carefully under the rear half.

To move the split shelf:

- Take both halves of the split glass shelf out,

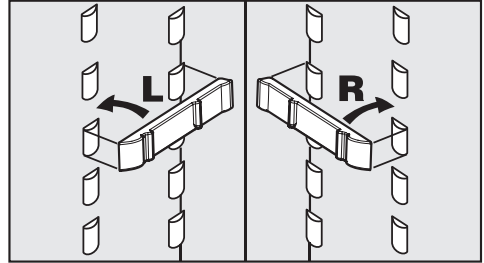

- fit the two brackets onto the supports on either side at the required height,
- and push the glass shelves in one after the other. The shelf with the raised edge must be at the back.

PerfectFresh zone compartments

The compartments in the PerfectFresh zone are on telescopic rails, and can be removed for filling, emptying or cleaning purposes.

- Pull out the compartment as far as it will go, and then lift it up and out.

Push the runners back in again to avoid injury or damage.

Adjusting the interior fittings

- Carefully pull out the lid between the compartments slightly, and lift it down and out.
- To replace it, insert the compartment lid from beneath into the holders, and push it back into place.

To replace the compartment,

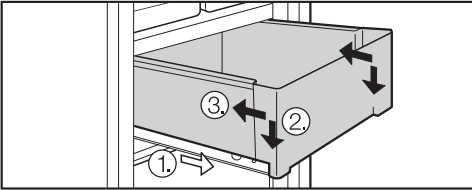

- place it back on the fully extended runners ①. The front of the runners must be right up against the front of the compartment ②.
- Then push the compartment back in ③.

Adjusting the condiment tray/bottle shelf

- Lift the tray/shelf up and out of the stainless steel frame to remove.
- Push up the stainless steel frame, and remove.
- Replace the frame at the required height. Ensure that it is securely pushed back into position.
- Replace the tray/shelf in the frame.

The tray/shelf can be removed completely and used as a serving tray at the table.

Universal container

The universal container can be used both to store and serve food.

It consists of a deep tray and a shallow tray. Both trays fit the stainless steel frame.

If you wish to use the universal container to serve food,

- place the shallow tray in the stainless steel frame, and use the deep tray as a lid.

You can lift the universal container, including contents, out of the frame and take it to the table.

Moving the bottle divider

(depending on model)

The bottle divider can be moved to the left or right to ensure that bottles are held securely in position when the door is opened and shut.

The bottle divider can be removed completely (e.g. for cleaning).

- To do this, push up the front edge of the bottle divider, and disengage it.

Freezing and storing food

Maximum freezing capacity

To ensure that fresh food placed in the freezer freezes through to the core as quickly as possible, the maximum freezing capacity must not be exceeded. The maximum freezing capacity for freezing within a 24-hour period is given on the data plate: "Freezing capacitykg/24 hrs".

Freezing fresh food

Fresh food should be frozen as quickly as possible. This way the nutritional value of the food, its vitamin content, appearance and taste are not impaired.

Food which takes a long time to freeze will lose more water from its cells, which then shrink.

During the defrosting process, only some of this water is reabsorbed by the cells; the rest collects around the food.

If food is frozen quickly, the cells have less time to lose moisture, so they shrink less. As there is not so much moisture loss, it is easier for the food to reabsorb it during the defrosting process, and very little water collects around the defrosted food.

Storing frozen food

When buying frozen food to store in your freezer, check

- that the packaging is not damaged,
 - the use-by date,
 - the temperature at which the frozen food is being stored in the shop. The length of time it can be kept is reduced if it has been stored at a temperature warmer than -18°C .
- Buy frozen food once you have finished the rest of your shopping, and wrap it in newspaper or use a cool bag or cool box to transport it.
 - Store it in the freezer as soon as possible.

Never re-freeze partially or fully defrosted food. Consume defrosted food as soon as possible as it will lose its nutritional value and spoil if left for too long. Defrosted food may only be re-frozen after it has been cooked.

Home freezing

Only freeze fresh food which is in a good condition.

Hints on home freezing

- The following types of food **are suitable** for freezing:
Fresh meat, poultry, game, fish, vegetables, herbs, fresh fruit, dairy products, pastry, leftovers, egg yolks, egg whites and a range of pre-cooked meals.
- The following types of food **are not suitable** for freezing:
Grapes, lettuce, radishes, sour cream, mayonnaise, eggs in their shells, onions, whole raw apples and pears.
- To retain colour, taste and vitamin C, vegetables should be blanched after they have been trimmed and washed.
To blanch: bring a large saucepan of water to the boil, immerse the vegetables in the fast boiling water for 2-3 minutes, depending on variety. Remove, and plunge into ice-cold water to cool quickly. Drain and pack ready for freezing.
- Lean meat freezes better than fatty meat, and can be stored for considerably longer.
- To prevent chops, steaks, cutlets or rolled meat from freezing together in solid blocks when packed, separate with a sheet of plastic freezer film.
- Do not season fresh foods or blanched vegetables before freezing. Only season cooked food

lightly before freezing, but care should be taken as the taste of some spices alters when frozen.

- Do not place hot foods or drinks in the freezer. This causes already frozen food to thaw, and increases the energy consumption considerably. Allow hot foods and drinks to cool down before placing them in the freezer.

Packing

- Freeze food in portions.

Unsuitable packing material

- wrapping paper
- grease-proof paper
- cellophane
- bin bags
- plastic carrier bags

Suitable packing material

- plastic freezer film
- freezer bags
- aluminium foil
- freezer containers

- Expel as much air as possible from bags etc. before sealing them, to prevent freezer-burn on food.
- Close the packaging tightly with
 - rubber bands
 - plastic clips
 - string or bag ties
 - freezer tape.

Freezer bags may also be sealed using home heat sealing kits.

- Make a note of the contents and the date of freezing on the packaging.

Freezing and storing food

Before placing food in the freezer section

- When freezing more than 2 kg of fresh food, switch on the Super freeze function for some time before placing the food in the freezer (see "Super freeze").
This also helps to prevent food that is already in the freezer from starting to defrost.

Placing food in the freezer

Food to be frozen can be placed anywhere in the freezer.

Large quantities can be placed directly on the glass cold plate to freeze the food quickly. To do this first take out one or more of the freezer drawers.

Each drawer and the glass cold plate can take a maximum of 25 kg.

- Place the food flat in the bottom of the drawers or on the glass cold plate in the freezer so that it freezes through to the core as quickly as possible.
- Make sure that the packaging and containers are dry to prevent them sticking together when frozen.

When freezing, make sure that food already frozen does not come into contact with fresh food being frozen as this could cause the frozen food to begin to defrost.

Freezing large items





If you wish to freeze large items such as a turkey or game, the glass cold plate between the drawers can be removed. To do this:

- Remove the freezer drawers and carefully lift and slide out the glass cold plate.

Freezer calendar

The freezer calendar on the freezer drawer gives the length of time in months which various foods can be stored for effectively.

Where the storage time given on the packaging differs, follow the advice on the packaging.

	2 - 3	6 - 8	
	3 - 5	10 - 12	

2-3 months:

Cakes, ice cream, stews

3-5 months:

Fish, mushrooms, bread

6-8 months:

Pork, veal, poultry

10-12 months:

Beef, fruit, vegetables

Defrosting

Frozen food can be defrosted in different ways:

- in a microwave oven,
- in an oven using the "Fan" or "Defrost" setting,
- at room temperature,
- in the refrigerator (the cold given off by the frozen food helps to keep the other food cold),
- in a steam oven.

Poultry It is particularly important to observe food hygiene rules when defrosting poultry. Do not use the liquid from defrosted poultry. Pour it away and wash the container it was in, the sink and your hands. Danger of salmonella poisoning.

Fruit should be defrosted at room temperature in its packaging, or in a covered bowl.

Most vegetables can be cooked while still frozen. Just put straight into boiling water or hot fat. The cooking time is slightly less than that of fresh vegetables due to changes in the cell structure.

Never re-freeze partially or fully defrosted food. Consume defrosted food as soon as possible as it will lose its nutritional value and spoil if left for too long. Defrosted food may only be re-frozen after it has been cooked.

Ice cubes

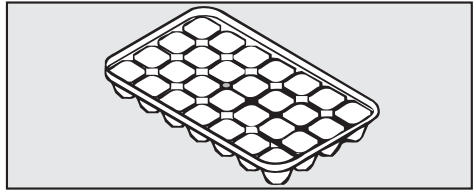

- Fill the ice tray three quarters full with water and place it on the bottom of one of the freezer drawers.
- Once frozen, use a blunt instrument, for example a spoon handle, to remove the ice tray from the freezer.
- Ice cubes can be removed easily from the tray by twisting the tray gently or by holding it under cold running water for a short while.

Cooling drinks

Drinks are best cooled quickly in the refrigerator section using the Super cool function. If bottles are, however, placed in the freezer section for rapid cooling, make sure they are not left in for more than one hour, as they could burst.

Freezing and storing food

Freezer tray

The freezer tray is useful for freezing small items such as berries, herbs and vegetables. They can be frozen individually and therefore maintain their shape when defrosted.

- Space the food out loosely on the tray.

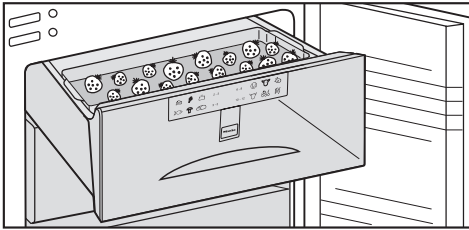

- Hang the tray in the top freezer drawer.

Leave the food for 10-12 hours to freeze thoroughly on the tray. Transfer it to a freezer bag or suitable container once frozen. Place the bag or container in the freezer drawer.

Cool pack

The cool pack prevents the temperature in the freezer rising too quickly in the event of a power cut.

Place the cool pack in the top drawer of the freezer section, directly on top of the food. The cool pack will be at its most effective after it has been in the freezer for approx. 24 hours.

If there is a power cut, place the cool pack directly on top of the frozen food in the upper drawer so that the food will be kept cold for as long as possible.

When placing fresh food in the freezer, use the cool pack to separate the fresh food from the food which is already frozen so that the frozen food does not begin to thaw.

The cool pack can also be used in a cool bag to keep food or drinks cool for a short period of time.

Defrosting the appliance

Refrigerator and PerfectFresh zone

The refrigerator and the PerfectFresh zone defrost automatically.

Condensate and frost can build up on the back wall of the refrigerator section and the PerfectFresh zone whilst in use. You do not need to remove this, as it will defrost and evaporate automatically with the warmth generated by the refrigerator.

The condensate is drained away via a channel and drain hole into an evaporation system at the back of the appliance.

Ensure that the condensate channel and drain hole are kept clean and are never blocked so that condensate can flow away without hindrance.

Freezer section

The freezer section does not defrost automatically.

In normal use, ice and frost will form on the evaporator. If allowed to accumulate, this will impair the efficiency of the freezer and increase the consumption of electricity.

Do not scrape ice and frost off the evaporator as this can damage it and render the appliance unusable.

The freezer section should be defrosted from time to time. It must be defrosted if a layer of ice approx. 0.5 cm thick has accumulated. It is best to defrost when

only very little food or no food at all is left in the freezer.

Before defrosting

- Switch on the Super freeze function approx. 1 day before defrosting to ensure frozen food retains its cold reserve for longer when taken out of the freezer.
- Remove the frozen food from the freezer and place it in another freezer, or wrap it in several layers of newspaper or cloths with the cool pack, and store in a cool place until the freezer is ready for use again.
- Take the freezer drawers out of the freezer section.

To defrost

Carry out the defrosting procedure as quickly as possible if food has not been placed in another freezer. The longer the food is left out at room temperature, the faster it defrosts.

- Switch the appliance off by pressing the master On/Off switch, switch off at the socket and remove the plug.

The temperature displays will go out. If this does not happen, then the safety lock is engaged.

- Open the freezer section door.
- Use a sponge or towel to soak up the defrosted water.

Defrosting the appliance

To speed up defrosting, two bowls of hot water (not boiling) with plates underneath them can be placed in the appliance. Closing the door in this instance will help retain warmth and speed up the defrosting process.

We do not recommend the use of hot air blowers such as hairdryers for defrosting your freezer.

Never place electric heaters or candles in the appliance to defrost it. These can damage the plastic parts.

Do not use defrosting sprays or de-icers, as they could contain substances which may damage the plastic parts and which may cause a build-up of gases and pose a danger to health.

After defrosting

- Clean the freezer section and then dry it thoroughly.
- Close the appliance doors.
- Plug the appliance back in, and then switch it on.
The temperature displays will light up.
- Switch on the Super freeze function so that the appliance can cool down quickly. The indicator light will come on.
- Once the freezer section has reached the required temperature, place the food back in the freezer drawers and slide the drawers back into the freezer section.
- Switch off Super freeze by pressing the Super freeze button when the temperature in the freezer is a constant -18 °C or colder.
The indicator light will go out.

Never use cleaning agents containing abrasive substances such as sand, soda, acids chlorides or chemical solvents. "Non-abrasive" cleaning agents are also unsuitable as they can cause matt areas to appear.

To help prevent re-soiling, treat stainless steel surfaces with a proprietary conditioning agent for stainless steel (available from the Miele Spare Parts Department or via the internet on www.miele.co.uk).

Do not let water get into the electronic unit or into the light.

Do not let water get into the drainage channel and drain hole when cleaning.

Do not use steam cleaning apparatus to clean the appliance. Steam could reach the electrical components and cause a short circuit.

The data plate located inside the appliance must not be removed. It contains information which is required in the event of a service call.

Before cleaning

- Switch the appliance off by pressing the master On/Off switch on the right hand side of the control panel, switch off at the socket and remove the plug.

- Take any food out of the appliance and store it in a cool place.
- Defrost the freezer.
- Take out any removable parts, e.g. shelves, for cleaning.

E-Cloth

A microfibre "E-Cloth" is available from the Miele UK Spare Parts Department, which is suitable for cleaning surfaces such as stainless steel, glass, plastic and chrome without the use of chemicals. It can be washed 300 times.

Cleaning the interior and accessories

Use warm water with a little washing-up liquid. Wash all accessories and drawers by hand only. Do not wash in a dishwasher.

- Clean the refrigerator section at least once a month and the freezer section each time it is defrosted.
- Clean the condensate channel and drain hole frequently, so that condensate can drain away unhindered. Use a straw or similar to clear the drain if necessary.
- After cleaning, wipe the interior and accessories with a damp cloth and dry with a soft cloth. Leave the doors open to air the appliance for a short while.

Cleaning and care

- Clean stainless steel surfaces with a suitable, non-abrasive, proprietary stainless steel cleaning agent, following the manufacturer's instructions on the packaging.
- After cleaning, stainless steel surfaces should always be treated with a conditioning agent for stainless steel.

It is important to do this every time the stainless steel surfaces are cleaned, as the stainless steel conditioner protects the surfaces and helps prevent re-soiling.

Ventilation gaps

- The ventilation gaps should be cleaned on a regular basis with a brush or vacuum cleaner. A build-up of dust will increase the energy consumption of the appliance.

Door seals

Do not use any oils or grease on the door seals as these will cause the seals to deteriorate and become porous over time.

The door seals should be cleaned regularly with clean water, and then wiped dry with a soft cloth.

After cleaning

- Replace all shelves and accessories in the refrigerator section.
- Place food back in the refrigerator section, close the appliance doors, insert the plug in the socket and switch the refrigerator section and the freezer section on.
- Switch on the Super freeze function so that the freezer section can cool down quickly. The indicator light will come on.
- Once the freezer section has reached the required temperature, place the food back in the freezer drawers and slide the drawers back into the freezer section.
- Switch off Super freeze by pressing the Super freeze button when the temperature in the freezer is a constant -18 °C or colder. The indicator light will go out.

Repairs to electrical appliances should only be carried out by a suitably qualified and competent person in strict accordance with current local and national safety regulations. Repairs and other work by unqualified persons could be dangerous. The manufacturer cannot be held liable for unauthorised work. Ensure that current is not supplied to the appliance until after maintenance or repair work has been carried out.

What to do if . . .

. . . the refrigerator section or freezer section does not get cold.

- Check whether the respective section is switched on. The relevant temperature display must be lit up.
- Check that the plug is correctly inserted in the socket and switched on.
- Check that the fuse is not defective and that the mains fuse has not tripped. If it has, contact the Miele Service Department.

. . . the temperature in the refrigerator section or freezer section is too low.

- Select a warmer temperature.
- The Super freeze function is still on and the Super freeze indicator light is on.
The Super freeze function switches itself off automatically after 30-60 hours.
- The Super cool function is still on and the Super cool indicator light is on.
The Super cool function switches itself off automatically after approx. 6 hours.
- Check that the doors have been closed properly.
- Has a large amount of fresh food been frozen at the same time?
This makes the compressor run for longer, causing the temperature in the refrigerator section to fall automatically.

. . . the door to the freezer section will not open because it has been opened and closed too many times in succession.

- This is not a fault. The suction caused by opening and closing the door is preventing the door from opening. Wait a few minutes and then try again. It should now open without force.

Problem solving guide

... the compressor is switching in too frequently and for too long.

- Check whether the ventilation gaps in the plinth and in the housing unit at the top have been covered over or become too dusty.
- The doors have been opened too frequently, or a large amount of fresh food has been put in at once for freezing.
- Check that the doors have been closed properly.
- Check to see whether a thick layer of ice has built up in the freezer. If it has, then the freezer section will need defrosting.

... the compressor runs continuously.

To save energy, the compressor runs at a lower speed, but for longer, when less cooling is required.

... the frozen food is thawing because the freezer section is too warm.

- Is the room temperature lower than the ambient temperature for which the appliance is designed?

If so, raise the temperature of the room.

Operating in a room which is too cold will cause the cooling system to switch off for too long causing the freezer section to become too warm.

... food has frozen together.

Use a blunt instrument, e.g. a spoon handle or plastic scraper, to prise it apart carefully.

... there is a thick layer of ice in the freezer section.

- Check whether the freezer section door closes properly.
- Defrost and then clean the freezer section.

Too thick a layer of ice reduces efficiency and increases energy consumption.

- Close the door.

... the alarm sounds and the freezer section temperature display flashes.

The freezer section temperature has risen above the set temperature because

- the freezer section door has been opened too frequently, or large amounts of fresh food have been put in at once for freezing.

The alarm will stop and the temperature display will light up constantly again as soon as the temperature has dropped down to the correct level again.

. . . bars light up or flash in the temperature displays.

Check the temperature displays about 6 hours after switching on the appliance. Only temperatures within the range the appliance can display will be shown.

. . . "FD" to "F5" in one of the temperature displays appears.

There is a fault. Call the Service Department.

. . . the Super freeze indicator light and the temperature display are both flashing at the same time.

There is a fault. Call the Service Department.

. . . the Super freeze indicator light does not light up, even though the appliance is working.

The indicator light is defective. Call the Service Department.

. . . you cannot switch the appliance off.

The safety lock has been activated.

. . . "nA" appears in the freezer section temperature display.

The freezer section temperature has risen too high at some point during the last couple of days because of a power cut.

- Press the alarm off button whilst "nA" is lit up in the display.

The temperature display will show the warmest temperature recorded in the freezer section during the power cut.

Depending on the temperature displayed, you should check the condition of food in the freezer. If it has defrosted or started to defrost, check that it is still safe to use and if so use it as soon as possible. Defrosted food may only be re-frozen after it has been cooked.

The warmest temperature will show in the display for about 1 minute. The display will then revert to showing the actual current temperature in the freezer section.

At the end of a power cut, the appliance will start operating again at the last temperature setting selected.

Problem solving guide

. . . the interior lighting in the refrigerator section is not working.

Has the refrigerator door been left open for too long? The lighting switches itself off automatically after approx. 15 minutes.

If it also does not come on when the door is opened briefly, but the temperature display is working, then the lighting is defective.

- Call the Service Department.

The LED lighting may only be repaired or changed by a service technician.
Danger of injury and damage.

Should the cover be damaged or need to be removed due to damage, **exercise caution**. Never look at the lighting with optical instruments (magnifying glass or similar).

. . . the floor of the refrigerator is wet.

The drain hole is blocked.

- Clean the condensate channel and drain hole.

If you still cannot remedy the fault having followed these suggestions, please contact the Miele Service Department.
To prevent unnecessary loss of temperature, it is advisable not to open the doors while waiting for the appliance to be serviced.

Normal noises	What causes them
Brrrrr...	Humming noise made by the motor (compressor). This noise can get louder for brief periods when the motor is switching on.
Blubb, blubb....	A gurgling noise can be heard when coolant is circulating through the pipes.
Click....	Clicking sounds are made when the thermostat switches the motor on and off.
Sssrrrrr....	On multi-zone and frost-free appliances you can sometimes just hear the movement of air circulating inside the appliance.
Creak ...	Creaking sounds can be heard when material inside the appliance expands.

Remember that the noise of the compressor and the coolant circulating in the system is unavoidable.

Noises that you can easily rectify	What causes them, and what can you do about them
Rattling, vibrating	The appliance is uneven: Realign the appliance using a spirit level, by raising or lowering the screw feet underneath the appliance.
	The appliance is touching another appliance or piece of furniture: Move it away.
	Drawers, baskets or shelves are unstable or sticking: Check all removable items and refit them correctly.
	Are any bottles or containers unstable or knocking against each other? Separate them.
	The transport cable clips are hanging loose at the back of the appliance: Remove the clips.

After Sales / Guarantee

In the event of a fault which you cannot correct yourself, or if the appliance is under guarantee, please contact:

– your Miele Dealer

or

– Miele
(see back cover for contact details).

When contacting your Dealer or Miele, please quote the model and serial number of your appliance. This information is given on the data plate inside your appliance.

Please note that telephone calls may be monitored and recorded for training purposes.

N.B. A call-out charge will be applied for service visits where the problem could have been resolved as described in these instructions.

Guarantee

For information on the appliance guarantee specific to your country please contact Miele. See back cover for contact details.

In the U.K. your appliance is guaranteed for 2 years from the date of delivery. However, you must activate your cover by calling 0845 365 6640 or registering online at www.miele.co.uk.

Electrical connection U.K.

All electrical work should be carried out by a suitably qualified and competent person in strict accordance with current local and national safety regulations (BS 7671 in the UK).

The appliance is supplied with a mains cable and moulded plug ready for connection to an a.c. single phase 220-240 V 50 Hz supply.

Please ensure that the connection data quoted on the data plate match the household mains supply.

Connection should be made via a suitable switched socket which is easily accessible. For extra safety it is advisable to protect the appliance with a suitable residual current device (RCD).

Do not connect the appliance to the mains electricity supply by an extension lead. Extension leads do not guarantee the required safety of the appliance (e.g. danger of overheating).

This appliance must not be connected to the inverter of an autonomous power supply, e.g. a solar power system. When switching the appliance on, a surge in power could trigger the safety cut-out mechanism. This could damage the electronic unit.

The appliance must not be used with so-called energy saving devices. These reduce the energy supply to the appliance which could then become too warm. Using such devices could alter the specification of the product.

Non-rewireable plugs (BS 1363)

The fuse cover must be re-fitted when changing the fuse, and if the fuse cover is lost, the plug must not be used until a suitable replacement is obtained. The colour of the correct replacement cover is that of the coloured insert in the base of the plug, or the colour that is embossed in words in the base of the plug (as applicable to the design of the plug fitted).

Replacement fuses should be ASTA approved to BS 1362 and have the correct rating. Replacement fuses and fuse covers may be purchased from your local electrical supplier.

WARNING
THIS APPLIANCE MUST BE
EARTHED

Installation

To avoid a hazard due to instability of the appliance, it must be installed in accordance with these instructions.

Location

The appliance should be installed in a dry, well ventilated room. The room temperature should not go above or below the climate range for which the appliance is designed. The higher the ambient temperature of the room, the more energy the appliance requires to operate.

It should not be installed where it is exposed to direct sunlight or directly adjacent to a heat-producing appliance such as an oven or a radiator.

Important: tropical / humid environments

During periods of high humidity, some condensation may appear on outside surfaces of cooling appliances. This condensation will disappear when humidity levels drop. For prevention, it is advisable to install the appliance with sufficient ventilation in a dry and/or an air-conditioned room.

Please ensure that doors are closing and sealing properly.

Please ensure that the appliance is installed in accordance with these installation instructions and that the handle is fitted correctly. Should you require further assistance please contact your Miele customer service centre.

Climate range

The appliance is designed for use within certain climate ranges (ambient temperatures) and should not be used outside this range. The climate range of the appliance is stated on the data plate inside the appliance.

Climate range	Ambient room temperature
SN	+10°C to +32°C
N	+16°C to +32°C
ST	+16°C to +38°C
T	+16°C to +43°C
SN-ST	+10°C to +38°C
SN-T	+10°C to +43°C

Operating in a room which is too cold will cause the cooling system to switch off for too long, causing the internal temperature in the appliance to rise with the risk of food deteriorating and going off or frozen food defrosting.

Ventilation

Air at the back of the appliance gets warm. The appliance housing unit must be constructed to allow sufficient space for ventilation.

A ventilation gap of at least 38 mm depth must be allowed for behind the appliance for air to circulate. The air inlet to the appliance is via the plinth in the housing unit.

The cross-section of the air inlet and outlet must be at least 200 cm² to ensure that air can circulate without hindrance. Otherwise the appliance has to work harder, resulting in an increase in electricity consumption.

The air inlet and outlet must not be covered or blocked in any way. They should be dusted on a regular basis.

Before installation

- Before installation, remove the cover strip, sealing strip and other accessories from the appliance and from the external rear wall of the appliance.

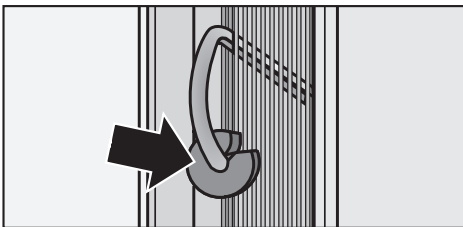

- On no account should the spacers be removed from the back of the appliance. These ensure the gap required between the back of the appliance and the wall is maintained.

- Remove any cable clips from the rear of the appliance.

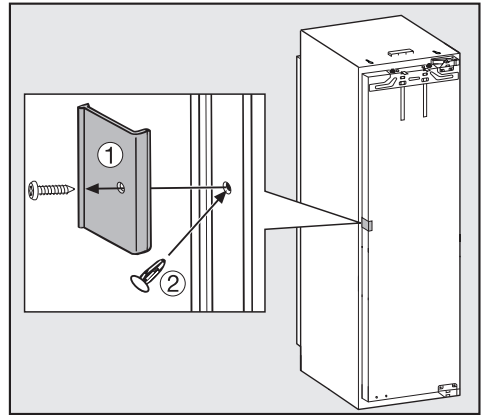

- Remove the red transport fixing ①, and use the stopper supplied ② to plug the empty hole.
- Check that all parts at the back of the appliance are unhindered. Carefully remove any hindrance.

Does your old appliance have a different hinging mechanism?

If your old appliance had a different type of hinging, the furniture door can still be used. Remove the old hinges from the housing unit. They are no longer required because the furniture door is now fitted to the appliance door. All the necessary parts are supplied or can be ordered from the Miele Spare Parts Department.

Building-in dimensions

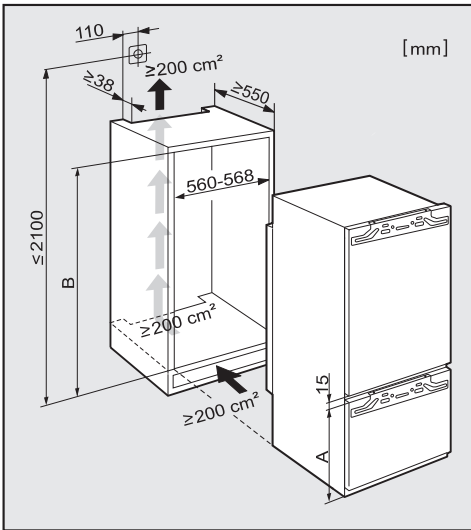

	Freezer section height A	Niche height B
KF 9757 iD	549	1772 - 1788

Adjusting the door hinges

The door hinges are set ex-works to enable the doors to be opened wide.

However, if the opening angle of the doors needs to be limited for any reason, the hinges can be adjusted to accommodate this.

- For example, if the appliance doors hit an adjacent wall when opened, the opening angle can be limited to 90°.

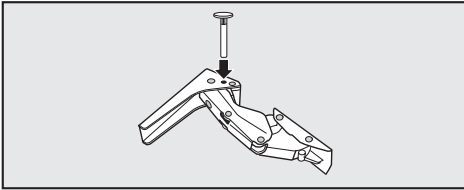

- Place the locking pins supplied for limiting the door opening into the hinges from above.

The door opening angle is now limited to 90°.

- If you would like the appliance doors to be cushioned so that they open more softly, the spring tension on the doors can be adjusted.

To do this, use the allen key supplied to adjust the door hinges.

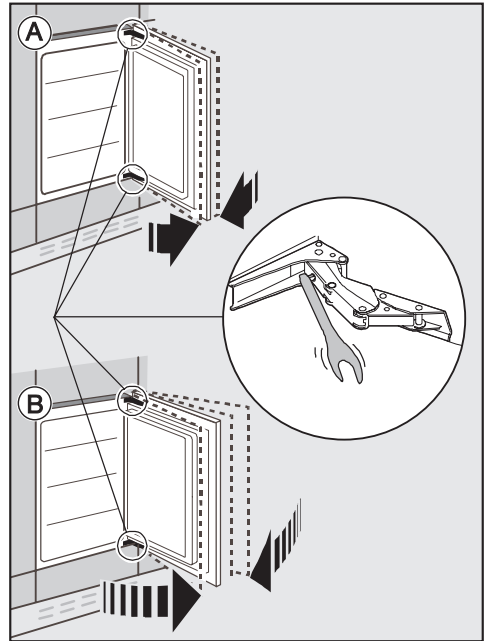

Ⓐ To reduce the opening angle:

- Turn the allen key clockwise.

This tightens the hinges and makes it harder to open the door wide.

Ⓑ To open the door fully:

- Turn the allen key anticlockwise.

Changing the door hinging

Before building the appliance in, you will need to decide on which side the door is to be hinged. If left hand door hinging is required, follow the instructions below.

To change the door hinging you will need the following tools:

- a cross-slotted screwdriver,
- a flat-bladed screwdriver,
- a selection of Torx screwdrivers,
- a spanner.

■ Open both appliance doors.

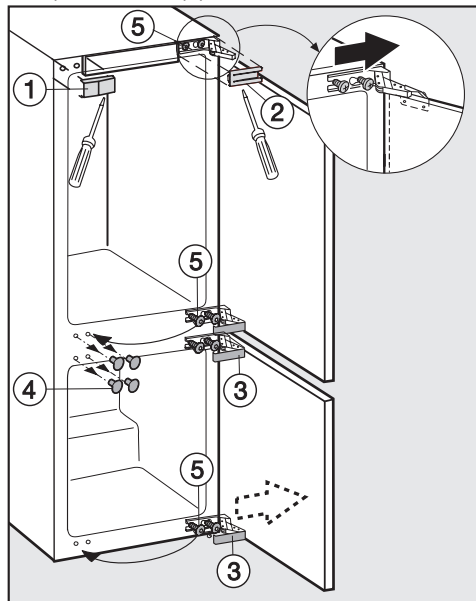

- Remove covers ①, ② and ③ and caps ④ with a screwdriver.
- Slightly loosen fixing screws ⑤ at the top, middle and bottom of the appliance.
- Push each of the doors outwards and take them off their hinges.

- Unscrew fixing screws ⑤ completely, and loosely screw them in at the top, middle and bottom on the opposite side of the appliance.

If you have put locking pins into the hinges to stop the door opening too far:

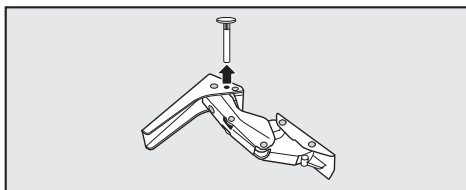

- Remove the locking pins from the top of the hinges.

To remove the soft-close mechanism

- Place the doors with the outer side downwards on a stable surface.

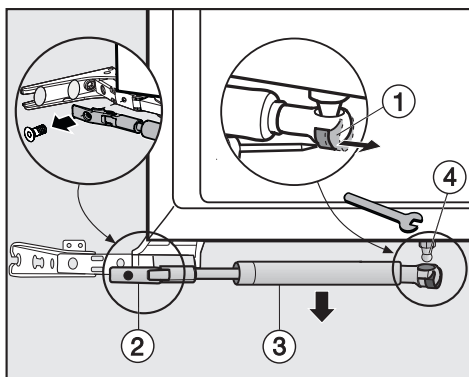

- Using a screwdriver, carefully push tension spring ① outwards.

Warning. The soft-close mechanism snaps shut when dismantled.
Danger of injury.

- Unscrew mounting ② and pull soft-close mechanism ③ downwards to remove it.

Changing the door hinging

- Undo ball joint ④ using a spanner and remove it.
- Stand the appliance doors up one by one, and slacken the hinges at the front (the hinges remain open).

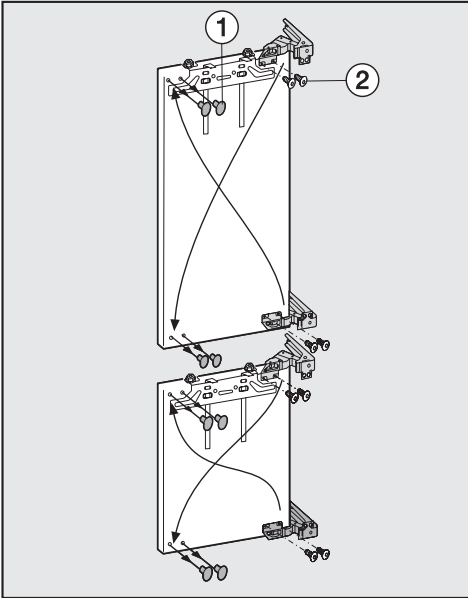

- Remove caps ① from the top and bottom of each door (if the caps are not in place, they will have been supplied separately with the appliance).
- Remove screws ② from all of the hinges, and refit each hinge in its diagonally opposite corner.

Do not close up the hinges. Danger of injury.

- Use a powered screwdriver to secure the hinges; screws ② are self-tapping.

- Replace caps ① in the vacant holes on the opposite side.

To secure the soft-close mechanism

- Place the two doors with the outer side downwards on a stable surface.

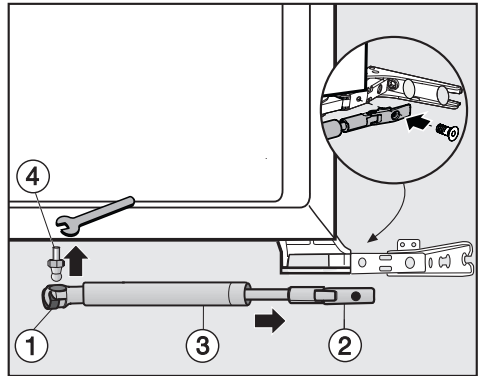

- Screw ball joint ④ of soft-close mechanism ③ into the new fixing holes.
- Push tension spring ① inwards again.
- Screw mounting ② onto the hinge and tighten securely.
- Open out soft-close mechanism ③ and hook it onto ball joint ④.

Changing the door hinging

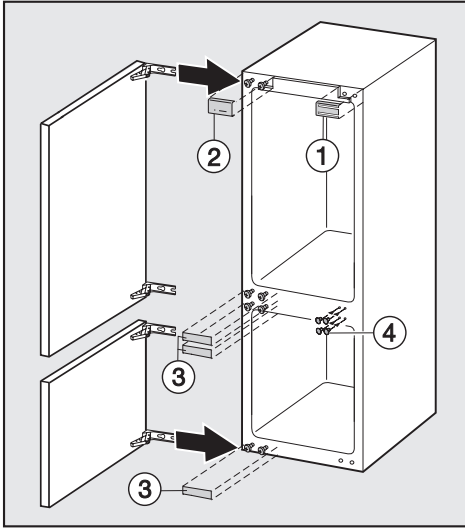

- Hang the doors onto the pre-fitted screws, and push the doors inwards.
- Tighten the screws at the top, middle and bottom securely.
- Replace covers ①, ② and ③.
- Then replace caps ④ in the vacant holes.

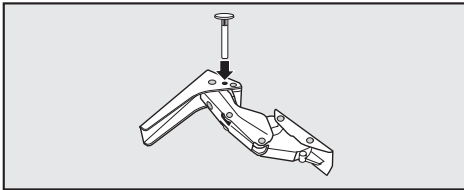

- Replace the locking pins into the top of the hinges to prevent the doors opening too far.

Building in the appliance

All fitting instructions given are for a **right hand hinged** appliance. If you have converted the appliance to left hand hinging you will need to adapt these instructions accordingly.

To install the appliance you will need the following:

- a cross-slotted screwdriver,
- a selection of Torx screwdrivers,
- a hexagon spanner.

Weight of the furniture doors

Before fitting furniture doors, ensure that the weight of the door does not exceed the maximum permitted:

Appliance	max. weight of upper door in kg	max. weight of lower door in kg
KF 9757 iD	20	12

Fitting a door which is heavier than the maximum permitted could damage the hinges.

Building into a peninsular run

When built into a peninsular run, the rear of the building-in niche must be fitted with a kitchen furniture panel.

Aligning the housing unit

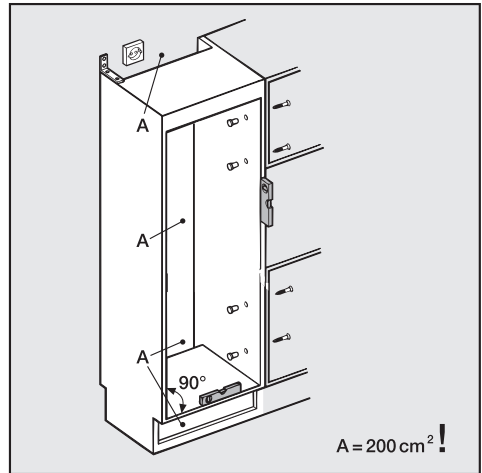

The housing unit must be carefully aligned using a spirit level before installing the appliance. The unit corners must be at right angles, as otherwise the furniture door will not align correctly with the 4 corners of the appliance.

Building in the appliance

Preparing the appliance

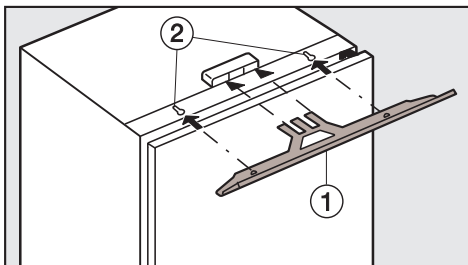

- Slide cover strip ① into the holder as shown, with the bumps facing downwards. The bumps will fit into keyhole slots ②.
- Position the mains electricity cable so that the appliance can be connected easily once installed.

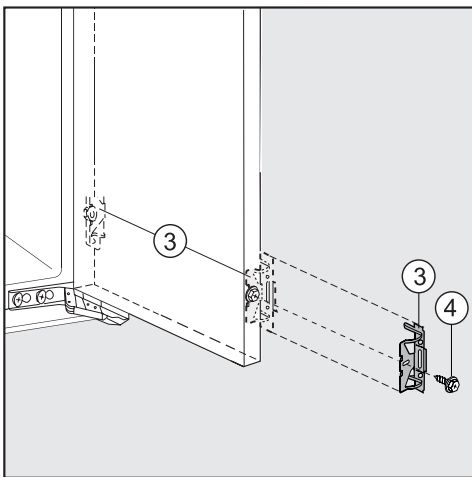

- Secure fixing brackets ③ (supplied) to the appliance doors by screwing a hexagon screw ④ into the pre-drilled holes.

(With large furniture doors, attach a third pair of fixing brackets ③ in the handle region of the doors).

- Push the appliance two-thirds of the way into its niche. When doing this, make sure that the mains cable does not get trapped.

With 16 mm thick unit walls:

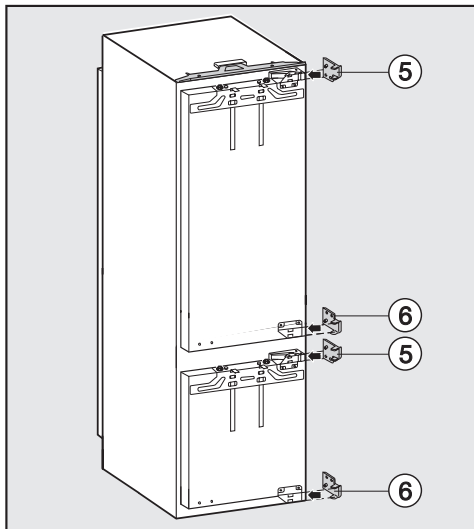

- Clip spacers ⑤ onto the top hinges and spacers ⑥ onto the bottom hinges.

Building in the appliance

- Open both appliance doors.

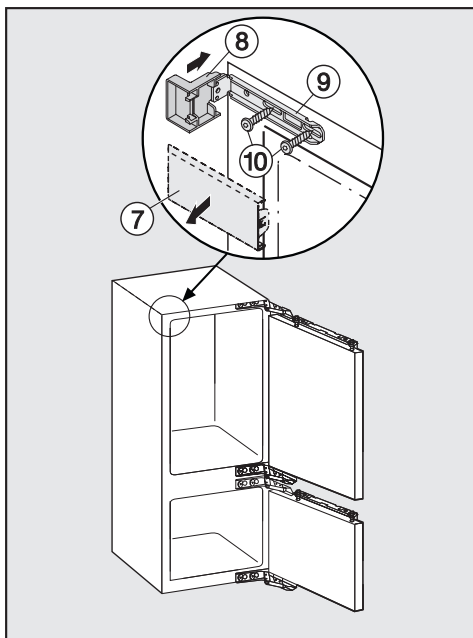

- Using a screwdriver, remove cover ⑦ from the top corner of the appliance.
- Fit cover ⑧ onto fixing bracket ⑨.
- Secure fixing bracket ⑨ to the top of the appliance with screws ⑩ (M5 x 15).

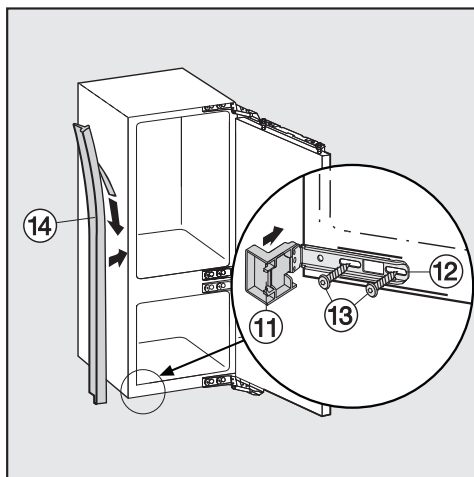

- Fit cover ⑪ onto fixing bracket ⑫.
- Secure fixing bracket ⑫ to the bottom of the appliance with screws ⑬ (M5 x 15).
- Carefully remove the protective foil from sealing strip ⑭.
- Apply the sealing strip to the side of the appliance on which the door is opened so that it is flush with the front edge of the appliance. Fit the sealing strip so that it meets up with the lower edge of top cover ⑧ and then cut the sealing strip 2 - 3 mm above bottom fixing bracket ⑫.
- Push the appliance into the niche until covers ⑧ and ⑪ touch the front edge of the side walls of the housing unit.

Building in the appliance

Building in the appliance

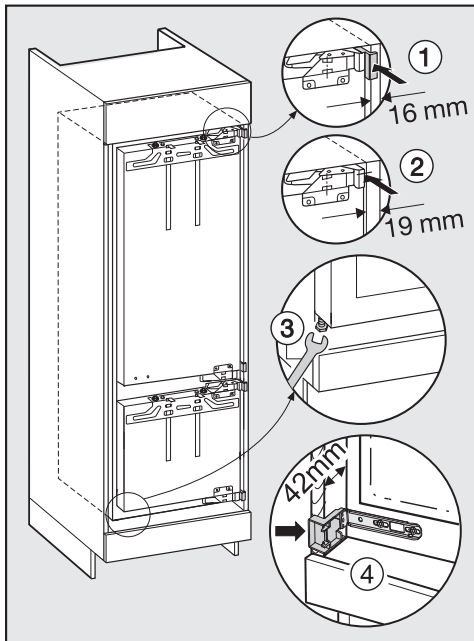

- **With 16 mm thick walls:**
The spacers should touch the front edge at the top and bottom of the side walls of the housing unit, detail ①.
- **With 19 mm thick walls:**
The front edges of the top and bottom hinges sit flush with the front edge of the housing side walls, detail ②.
- Make sure that the covers on the top and bottom fixing brackets sit flush with the front edges of the housing unit side walls, detail ④.

This will create a gap all round of **42 mm** to the front edges of the housing unit side walls.

On furniture with door fittings (e.g. stubs, seals etc) the dimension of these must be taken into account when making sure there is a gap all round of **42 mm**.

- Pull the appliance forwards by the dimension of the door fitting to keep the gap at 42 mm all round.

The hinges and the covers will now protrude by the dimension of the door fitting.

Tip: Remove the door fittings. This will ensure that the doors are flush with the surrounding kitchen unit furniture doors.

If the all round gap of 42 mm is not maintained between the appliance casing and the front edge of the housing unit side wall the doors may not shut properly. This could lead to a build-up of ice and condensation and also cause operational faults.

- Align the appliance height on both sides by altering the adjustable feet using the spanner supplied ③.

Securing the appliance in the niche

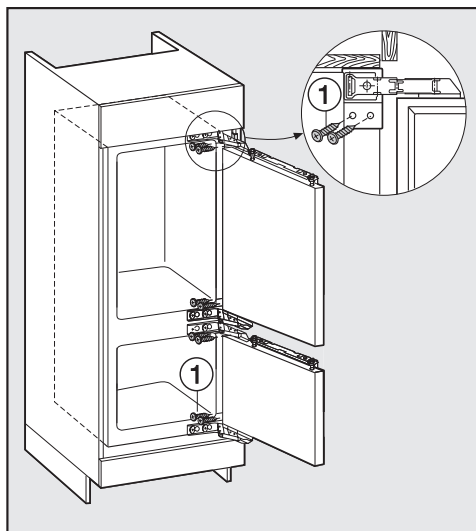

- Press the appliance against the housing unit on the hinge side.
- To fix the appliance to the housing unit at the top and bottom, screw the long 4 x 20 mm chip board screws (1) into the hinges at the top and bottom.

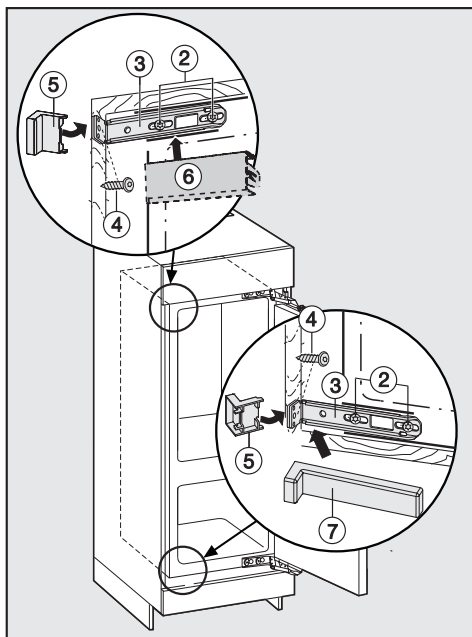

- Loosen screws (2) on the top and bottom fixing brackets (3).
- Press fixing bracket (3) against the side wall and tighten screws (2).
- Attach fixing bracket (3) to the housing unit side wall with screws (4). Drill holes in the housing unit side walls if necessary.
- Break off the protruding end of top cover (5), turn the cover around and fit it on top fixing bracket (3).
- Fit oblong cover (6) onto top fixing bracket (3).

Building in the appliance

- Break off the protruding end of bottom cover ⑤. It is no longer required.
- Fit angled cover ⑦ onto bottom fixing bracket ③.
- Close the appliance doors.

Fitting the furniture doors

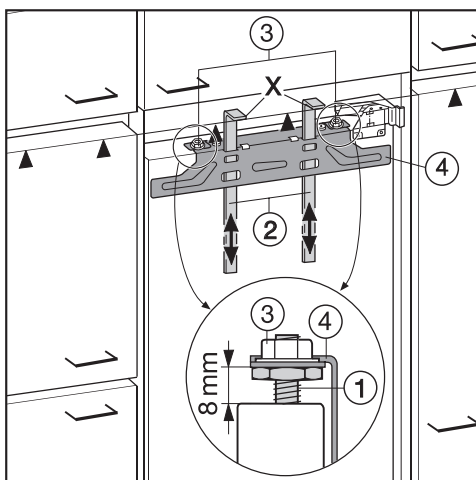

- A gap of 8 mm ① must be set between the appliance door and the central fixing bracket.
- Push fitting aids ② up to the height of the furniture door: the lower edge X of the fitting aids must be at the same height as the upper edge of the furniture door being fitted (see ▲ on the diagram).
- Undo nuts ③ and take fixing bracket ④ off together with the fitting aids.

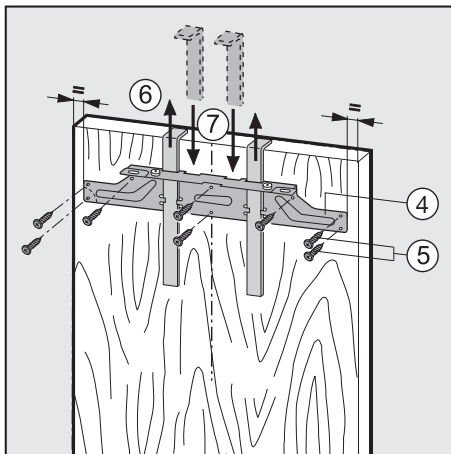

- Using a pencil, lightly mark a line down the centre of the inside of the furniture door.
- Hang fixing bracket ④ with the fitting aids onto the **inside** of the furniture door. Align the fixing bracket centrally.
- Attach the fixing bracket securely using at least 6 short 4 x 14 mm chipboard screws ②. (On cassette doors only use 4 screws on the edges).
- Pull the fitting aids upwards to remove them ⑥.
- Turn them around and fit them into the middle slots on fixing bracket ⑦ for safe keeping.

Securing the appliance doors to the furniture doors:

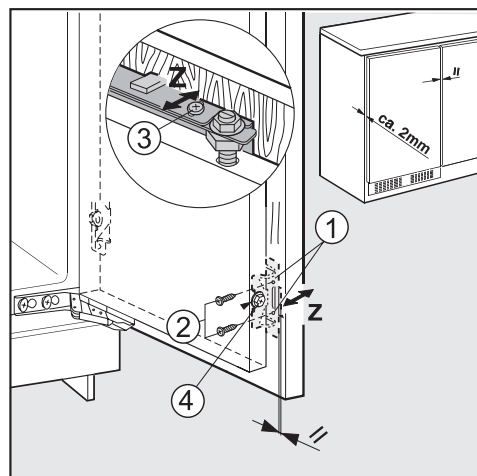
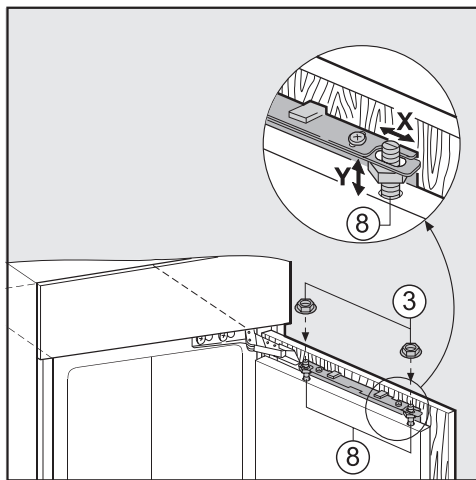

- Hang the furniture door onto adjusting bolts ⑧.
- Loosely attach nuts ③ on the adjusting bolts.
- Close the door and check the distance between the door and neighbouring furniture doors.
- Align to match neighbouring doors if necessary:
Side adjustments X are made by sliding the furniture door, and height adjustments Y by turning adjusting bolts ⑧ with a screwdriver.
- Tighten nuts ③.

- Drill fixing holes ① in the furniture doors and screw in the 4 x 14 mm screws ②.
Make sure the two metal edges are aligned (Symbol I).
- Align depth Z on the furniture door:
Loosen screws ③ at the top of the appliance door, and loosen the hexagon-headed screw ④ at the bottom of the fixing bracket. By moving the furniture doors, create a gap of 2 mm between the furniture doors and the front edge of the housing unit.

Building in the appliance

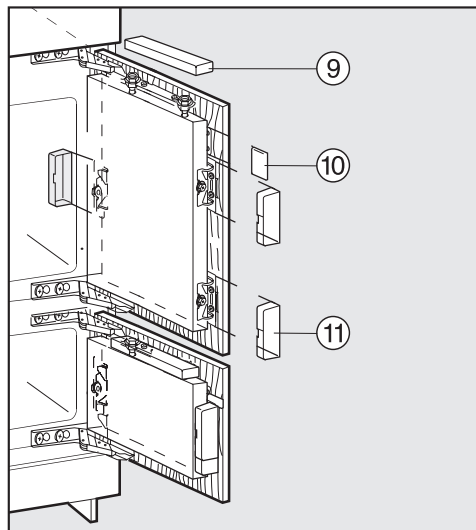
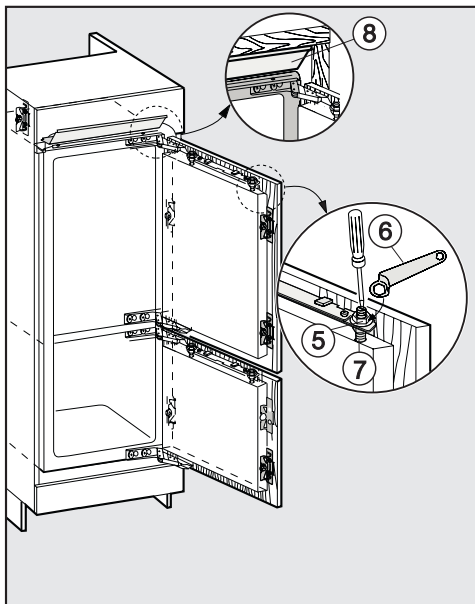

- Close both of the doors, and align them with the neighbouring furniture doors.
- Whilst counterholding adjusting bolts (7) with a screwdriver, tighten nuts (5) on the appliance doors with ring spanner (6).
- Cover strip (8) must be completely hidden in the niche, and must not protrude.
- Tighten all screws again.
- Replace top cover (9), and snap it into place.
- Replace side covers (10), making sure they snap into place.
- Replace side covers (11), making sure they snap into place.

To make sure the appliance is correctly fitted:

- The doors must close properly.
- The doors must not touch the housing unit.
- The seals at the top edge of the handle side must fit properly.
- To double check place a torch in the appliance and close the doors. Turn the lights out in the room. If you can see any light shining out from the sides double check the installation.

United Kingdom

Miele Co. Ltd.
Fairacres, Marcham Road
Abingdon, Oxon, OX14 1TW
Tel: 0845 365 0555
Fax: 0845 365 0777
Customer Contact Centre Tel: 0845 365 6600
E-mail: info@miele.co.uk
Internet: www.miele.co.uk

Australia

Miele Australia Pty. Ltd.
ABN 96 005 635 398
1 Gilbert Park Drive, Knoxfield, VIC 3180
Tel: (03) 9764 7130, Fax: (03) 9764 7149
Internet: www.miele.com.au

China

Miele Shanghai
Suite 4105-06, Plaza 66
1266 Nanjing Road West
Jing An District
Shanghai 200040, PRC
Tel: +86 21 6288 4200, Fax: +86 21 6288 4100
E-mail: mieleshanghai@cn.miele.com
Internet: www.miele.cn

Miele (Hong Kong) Limited

41/F - 4101, Manhattan Place
23 Wang Tai Road
Kowloon Bay
Hong Kong
Tel: (852) 2610 1331
Fax: (852) 2610 1013
Email: mielehk@miele.com.hk

India

Miele India Pvt. Ltd.
Ground Floor, Copia Corporate Suites
Plot No. 9, Jasola
New Delhi - 110025
Tel: 011-46 900 000, Fax: 011-46 900 001
E-mail: customercare@miele.in
Internet: www.miele.in

Germany - Miele & Cie. KG
Carl-Miele-Straße 29, 33332 Gütersloh



Ireland

Miele Ireland Ltd.
2024 Bianconi Avenue
Citywest Business Campus, Dublin 24
Tel: (01) 461 07 10, Fax: (01) 461 07 97
E-Mail: info@miele.ie, Internet: www.miele.ie

New Zealand

Miele New Zealand Limited
Unit L, 10-20 Sylvia Park Road
Mt. Wellington, 1060, Auckland, NZ
Tel: 0800 264 353, Fax: 0800 463 453
Internet: www.miele.co.nz

Singapore

Miele Southeast Asia
Miele Pte. Ltd.
163 Penang Road
04 - 02/03 Winsland House II
Singapore 238463
Tel: +65 6735 1191, Fax: +65 6735 1161
E-Mail: infosea@miele.com.sg
Internet: www.miele.sg

South Africa

Miele (Pty) Ltd
63 Peter Place, Bryanston 2194
P.O. Box 69434, Bryanston 2021
Tel: +27 (0) 11 548-1900
Fax: +27 (0) 11 548-1935
E-mail: info@miele.co.za
Internet: www.miele.co.za

United Arab Emirates

Miele Appliances Ltd.
P.O. Box 11 47 82
Gold & Diamond Park
Sheikh Zayed Road
Building 6 / Offices Nos. 6-214 to 6-220
Dubai
Tel: +971-4-341 84 44
Fax: +971-4-341 88 52
E-Mail: info@miele.ae
Internet: www.miele.ae